



our office and factory

► ENGINEERS FOR THE FEED INDUSTRY

Almex extrusion techniques specialises in single screw extrusion equipment, from the extrusion unit to complete installations. We are a family owned, independent company since 1970.

Almex extruders and Contivar™ expanders are in use worldwide at fishfeed-, oil extraction-, petfood-, animalfeed plants, the foodindustry, the processing and chemical industries.

▶ EXTRUSION TECHNIQUES

Almex quality extruder parts are used to manufacture Contivar™ Expanders for the feed industry, a popular machine to improve feed quality. The robust, basically simple design of the Almex equipment guarantees years of trouble free service. Almex was the first company using the Active Disc system on expanders in order to control exact power input.

Using the Active Disc system the expander becomes a tool that can be precisely tuned in order to assure quality of the product.

AL

▶ AL300 WITH ACTIVE DISC SYSTEM

1. HYDRAULIC COUPLING
2. GEARBOX
3. BEARING ASSEMBLY
4. INLET SECTION
5. CONTIVAR™ BODY
6. ACTIVE DISC SYSTEM

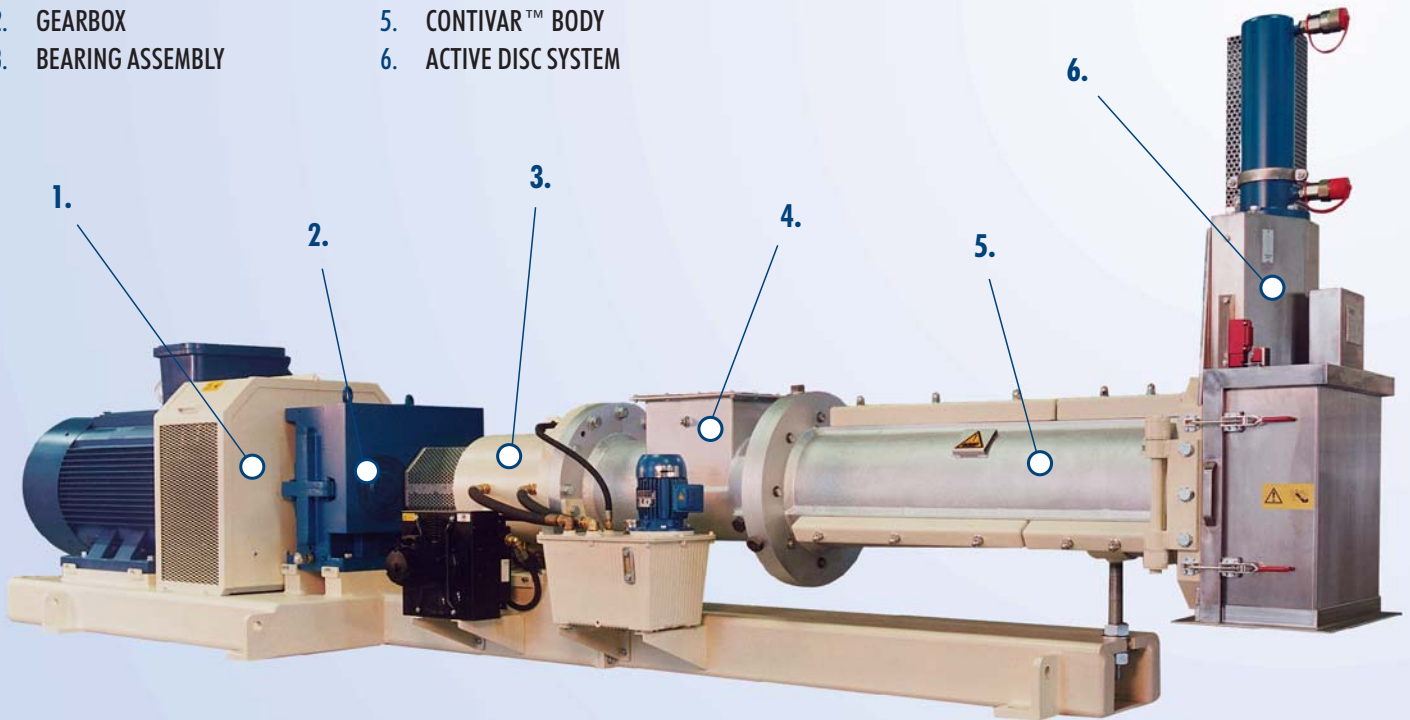

  expander in standard colour, special colours are possible on request.

300



The Contivar™ Expander is supplied with a new compression control system for expansion. The system works with an Active Disc forming strings of expanded product. The AD system is more easy to control and offers excellent availability of wearparts compared with the traditional conesystems. The picture above shows a Contivar™ AL300 conditioner with hydraulic slide and inline drive. Also available with V-belt drive.

In combination with an Almex crusher this unit is an excellent tool for the production of crumbled feed. Due to the proven advantages of the Active Disc system we also modify traditional cone systems into AD systems. Market demand forced us to concentrate on production of the AD system as a standard. However on specific request we can still supply our expanders with a cone system as an option.

Almex extruders and Contivar™ Expanders are used for:

- Extrusion-cooking
- Pre-extraction processes
- Densifying
- Conditioning prior to other processes
- Expanded feed production
- Forming
- Cooking-forming
- Semi-moist
- H.T-S.T. processes
- Co-extrusion



► PRE-CONDITIONER

Advantages of the Contivar™ Conditioner:

- eliminate heat sensitive bacteria (salmonella)
- higher fats and liquids inclusions
- gelatinisation of available starches
- improved end product durability and strength
- increased output of forming unit
- reduces wear costs of forming unit
- improved water stability for fish feed
- enhanced oil extraction
- access to wearparts
by opening a lightweight stainless steel door only
- easy cleaning
- less downtime for maintenance

Standardfinish RAL 1015, special colours are possible on request.



► TWIN SHAFT CRUSHER

► CLOSE UP OF AD SYSTEM

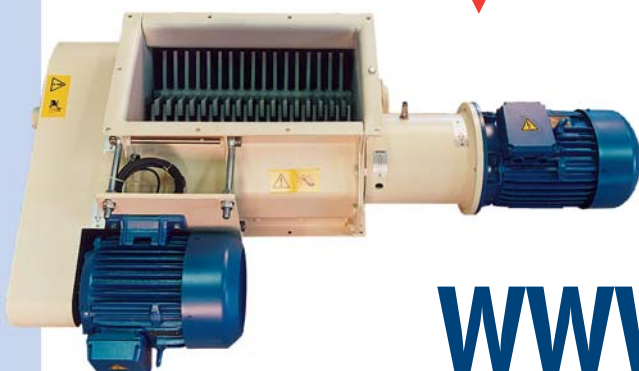

Almex designed a twinshaft lumpcrusher. One shaft has a fixed speed, the other shaft has a variable speed allowing fine tuning of the particle size. The lumpcrusher is used for production of direct expanded crumbs in order to achieve a more consistent structure. Also available in single shaft execution.

FLWSHEET

CONTIVAR™ CONDITIONER

FOR CRUMBLES

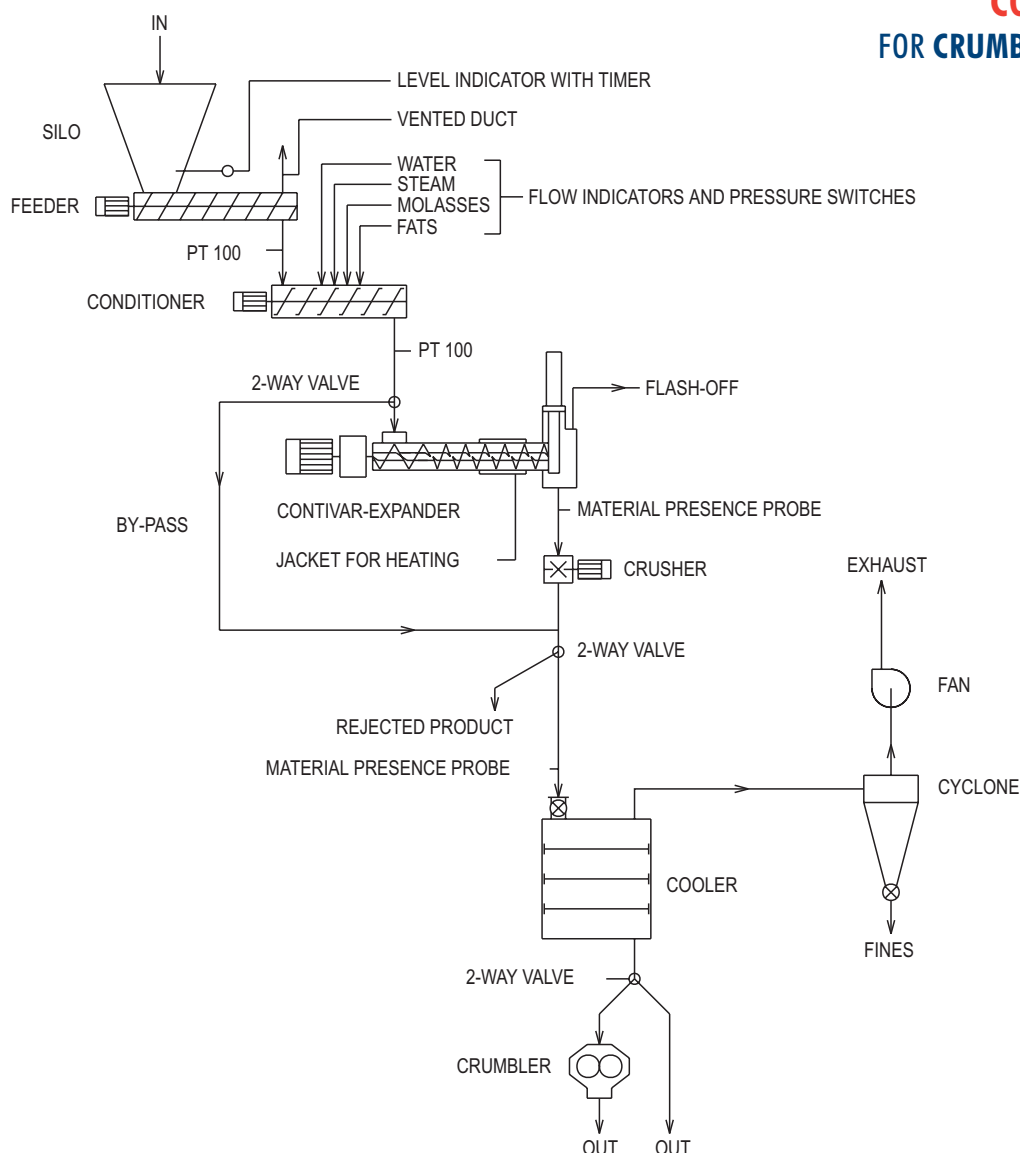

► TECHNICAL DATA

Type	AL150	AL200	AL300	AL350	AL400
Main motor (kW)	45 - 75	75 - 132	132 - 315	315 - 400	400 - 500
Motor slide adjustment (Motorpower KW)	0.55	0.55	0.75	0.75	1.5
Expander barrel diameter (mm)	150	200	300	350	400
Capacity (ton/hour)	1 - 6	5 - 10	10 - 30	30 - 45	45 - 80

Use of an expander prior to a pellet mill can be a proprietary process and may require a license for use only within some ec countries.
 Outside Europe use of an expander prior to a pelletmill is not restricted. Contact us for details.

► ALMEX B.V.

P.O. box 150
 7200 AD Zutphen, Netherlands

Verlengde Ooyerhoekseweg 29
 7207 BJ Zutphen, Netherlands

tel.: +31 (0)575 57 26 66
 fax: +31 (0)575 57 27 27

internet: www.almex.nl
 e-mail: info@almex.nl